

VARITANK FILTER 150/325

Filter shaft with Trident filter technology for 325 m² of roof surface



PRODUCT DESCRIPTION

Trident filters are a highly efficient dynamic rainwater filter, ensuring that a maximum volume of water passes through the filter and into the tank. The filter acts as the first step in the rainwater treatment process and has the capability to reduce the overall lifetime cost of the entire rainwater harvesting system.

With a range of pre-tank filters and tank filters with skimmers, Trident filters are flexible to suit in almost any tank; improving tank life, reducing maintenance and capable of handling high volume harvesting needs.

- +90% Efficiency 700µm
- Rapid separation of waste and clean water
- Dirt resistant and large effective filter grid
- Automatic cleaning reduces maintenance required
- Ideal for rainwater harvesting

APPLICATION AREA

The Trident tank filter is suitable for filtering rain water from roofs of homes or buildings with a roof surface up to 325 m² (based on 300 litres/sec/ha). There are different tanks which the Trident tank filter is suitable for; the blueline, flatline, neo-line and flexo-line tanks. The filter shaft is applied to the synthetic frill of the borehole and sealed with a rubber ring. The shaft is 360 degrees rotatable to ease the connection of the pipe system and can be shortened at any height or raised by use of the PE shaft extension. The decline between the supply and discharge of the filtered rain water is 40 mm.

VARITANK

The unique variable (filter) shaft system

- Rotatable
- In short
- Telescopic
- Child safe
- Wide range of swivel covers

TECHNICAL DATA

Height H1 in mm:	223
Height H2 in mm:	137
Height H3 in mm:	97
Height H4 in mm:	450-600
Weight in kg:	20
Connection waste water in/out in mm:	110/125
Connection of casing pipe in mm:	2x 110
Manhole Ø in mm:	600
Max. roof area in m ² :	325
Height difference of the supply in mm:	40
Material housing:	PE
Material filter grid:	RVS

TECHNICAL DRAWING

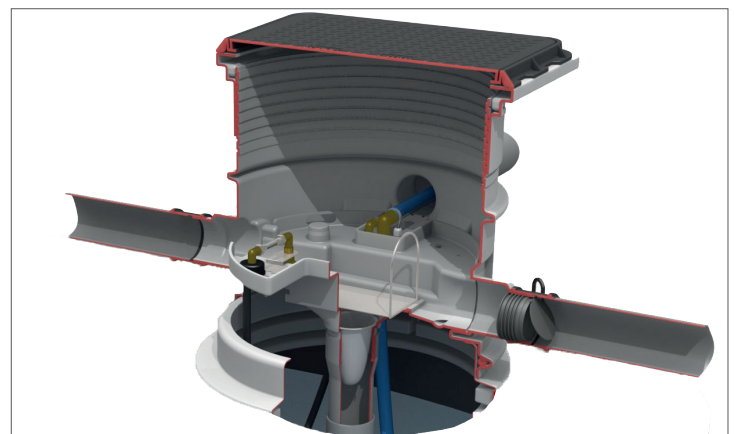
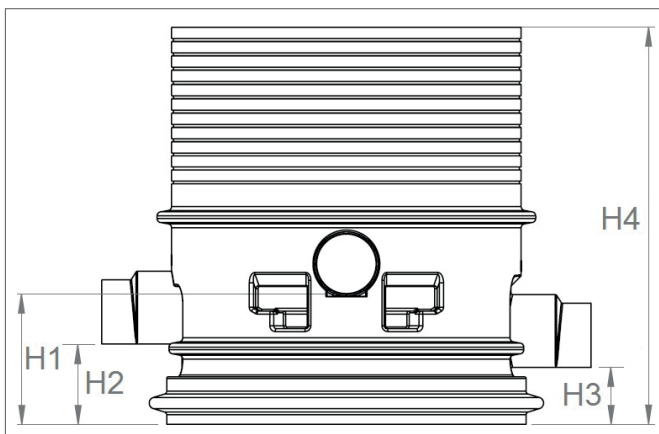

OPTIONS

Nozzle set for Trident 150, 325 and 450 tank filter
Allows easy and automatic cleaning of the filter. The nozzle cleans the filter surface by means of water pressure via a special powerful brass cone nozzle.

Automatic time-controlled filter cleaner 1/2"
Time-controlled filter cleaner makes automatic filter cleaning possible. The nozzle sprays the filter surface at freely adjustable times clean.

Fine filter bag
The fine filter bag can be placed under the Trident filter plate. The fine filter bag filters very finely to a mesh size of 150 µm. This fine filter can be used in places where high demands are placed on the water quality. (see 2)

Backflow alarm for Trident filters
The filter can be equipped with an alarm sensor that flows back from the overflow signals. This alarm sensor can be connected on an IRM rainwater system that switches to drinking water as an alarm signal comes from the sensor. This will contaminate sanitary appliances, pump and pipes (see 2).

Varitank shaft extension 60 cm
The shaft extension with seal ring can be mounted on the filter shaft. The shaft can be easily shortened. In this way every Varitank cover can be made on the desired height, equated to the ground level.

Check valve for Trident 150 tank filter
Valve to place behind the filter in the drain. Plug-in model, suitable for 110 mm pipe pieces. Reduced the risk of backstopping from the overflow towards the tank. Material polypropylene black, provided of flexible rubber lining.

Varitank cover set
For every Varitank filter is a wide range of covers available in traffic class A, B en D. See the special Varitank cover pages to choose your suitable cover.

TECHNICAL OVERVIEW

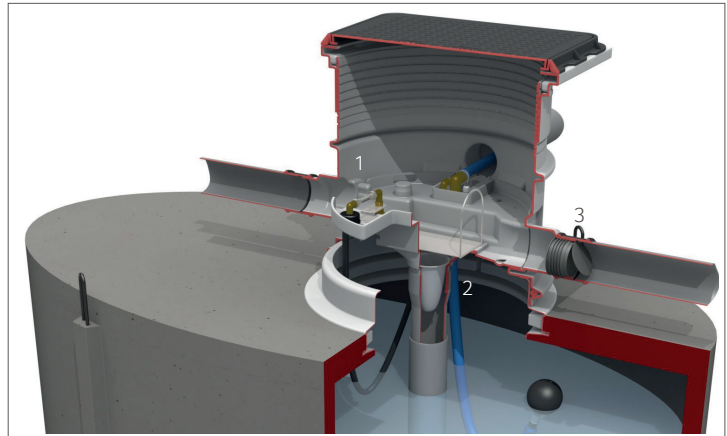
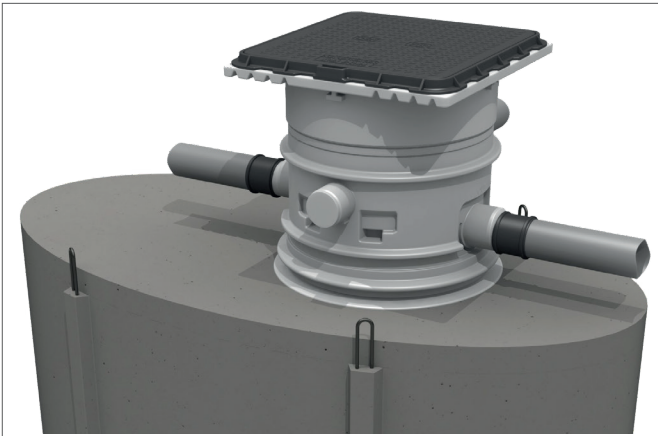

DELIVERY

Product consist of: filter shaft with 4 connections, child-resistant filter dish equipped with m13 closures, Trident 150 filter plate, gentle supply, PVC covering piece, rubber sealing ring of 25 mm, including lubricant, 6x push in rivet and assembly manual

ORDER DETAILS

Art nr	NAME	PG
401130	Varitank filter 150/325	3
401152	Nozzle connection set for Varitank filter 150/325	2
401155	Automatic time-controlled filter cleaner 1/2"	2
401157	Fine filter bag	2
401158	Backflow alarm for Trident filters	2
403512	Varitank inner shaft 60 cm	3
401165	Check valve for Trident 150 tank filter	2

Wide range of covers available, see Varitank covers from GEP.

